

lumiDigit II[®]

CABINET RETROFIT SURVEY INSTRUCTIONS RETROFIT IF EXISTING SIGN MEETS THE FOLLOWING CRITERIA:

(A) CABINET HAS SQUARE CORNERS.

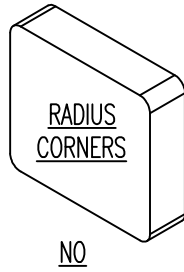
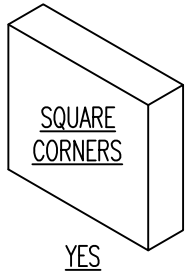

(B) CABINET IS AT LEAST 8" DEEP.

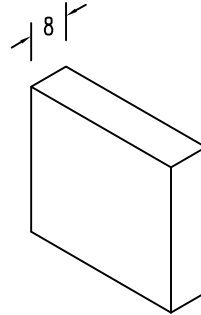

NOTE: IF CABINET IS LESS THEN 8". A RETRO MAY STILL BE POSSIBLE BUT SPECIAL SURVEY IS REQUIRED. SPEAK WITH YOUR EVERBRITE REP.

(C) DEPTH OF POLES OR MONUMENT PYLON STRUCTURE DEPTH ARE NOT GREAT THEN CABINET DEPTH.

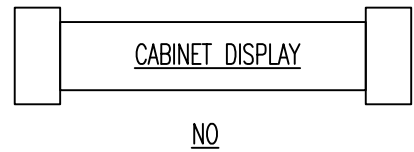
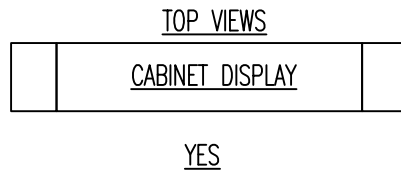
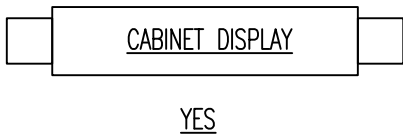

(D) FACE RETENTION SYSTEM LOOKS LIKE ONE OF THESE:

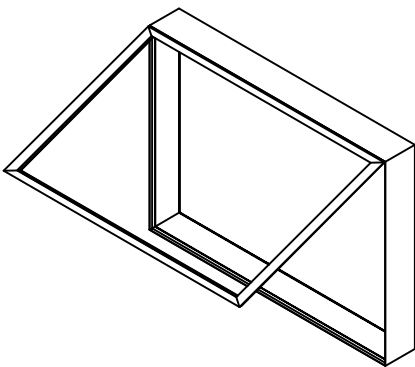

HINGED DISPLAY
USE FORM A

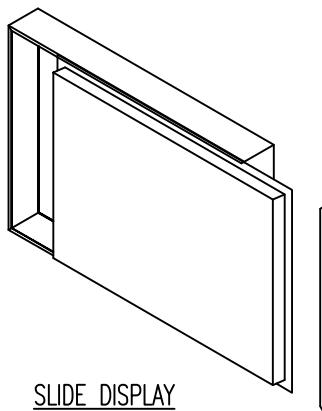

SLIDE DISPLAY
USE FORM B

PHOTO'S REQUIRED:

- (1) FRONT VIEW OF CABINET
- (2) SIDE VIEW OF CABINET
- (3) CLOSE UP OF TOP CORNER OF CABINET
- (4) INSIDE CORNER WITH FACE REMOVED
SLIDE FACE ONLY



Everbrite

401 S. Main St | P.O. Box 97
Pardeeville, WI 53954
(608) 429-2121

lumiDigit II[®]

SIGN CABINET HINGED RETAINER RETROFIT SURVEY FORM A

CUSTOMER NAME: _____

SITE NAME/NUMBER: _____

SITE ADDRESS: _____ CITY: _____ STATE: _____ ZIP: _____

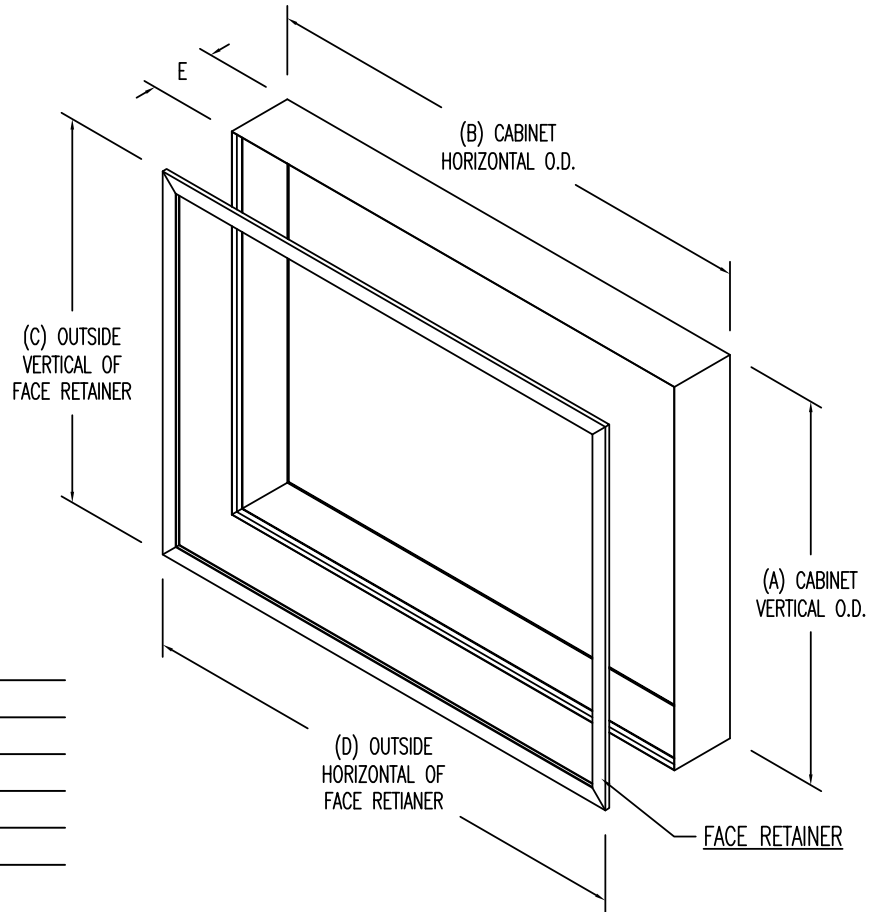
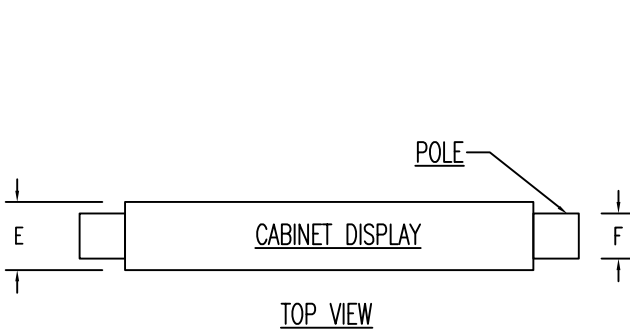

REQUIRED INFORMATION

- (A) CABINET VERTICAL O.D. (A) _____
- (B) CABINET HORIZONTAL O.D. (B) _____
- (C) OUTSIDE VERTICAL OF FACE RETAINER (C) _____
- (D) OUTSIDE HORIZONTAL OF FACE RETAINER (D) _____
- (E) CABINET OVERALL DEPTH (E) _____
- (F) POLE/PYLON DEPTH (F) _____
(ONLY REQUIRED FOR BETWEEN POLE MOUNT)

GENERAL QUESTIONS (REQUIRED)

CONDITION OF CABINET: GOOD ___ FAIR ___ POOR ___

CABINET TYPE: SINGLE FACE ___ DOUBLE FACE ___

ELECTRICAL SERVICE: 120V ___ OTHER _____

NUMBER OF CIRCUITS TO SIGN: ___

HORIZONTAL OR VERTICAL LAMPS: H ___ V ___

NOTE:
FACE RETAINER IS WHAT HOLDS THE FACE IN PLACE.

COMMENTS



Everbrite

401 S. Main St | P.O. Box 97
Pardeeville, WI 53954
(608) 429-2121

lumiDigit II[®]

SIGN CABINET SLIDE RETAINER RETROFIT SURVEY FORM B

CUSTOMER NAME: _____

SITE NAME/NUMBER: _____

SITE ADDRESS: _____ CITY: _____ STATE: _____ ZIP: _____

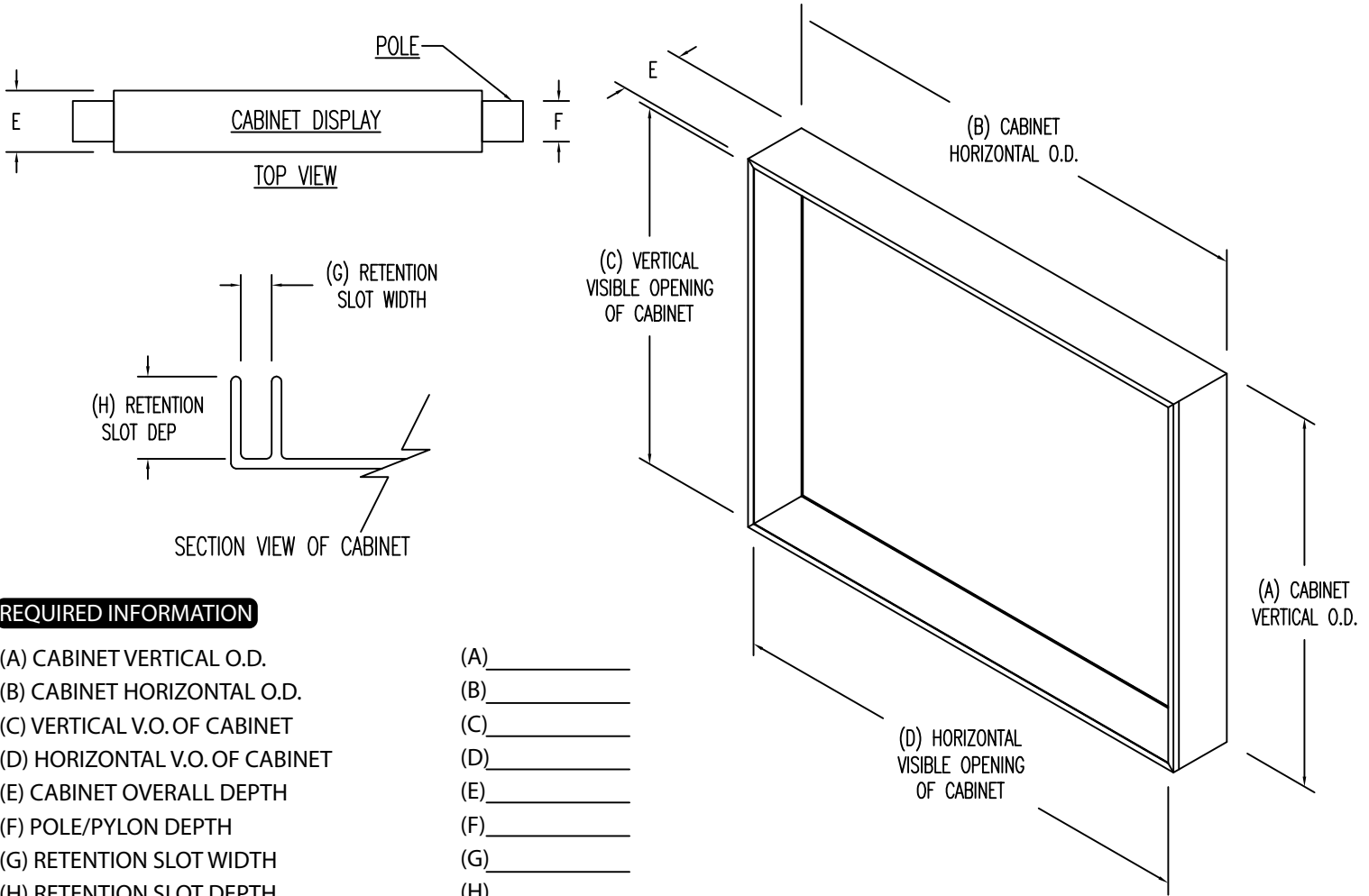

REQUIRED INFORMATION

- (A) CABINET VERTICAL O.D. _____
- (B) CABINET HORIZONTAL O.D. _____
- (C) VERTICAL V.O. OF CABINET _____
- (D) HORIZONTAL V.O. OF CABINET _____
- (E) CABINET OVERALL DEPTH _____
- (F) POLE/PYLON DEPTH _____
- (G) RETENTION SLOT WIDTH _____
- (H) RETENTION SLOT DEPTH _____

GENERAL QUESTIONS (REQUIRED)

CONDITION OF CABINET: GOOD ___ FAIR ___ POOR ___

CABINET TYPE: SINGLE FACE ___ DOUBLE FACE ___

ELECTRICAL SERVICE: 120V ___ OTHER _____

NUMBER OF CIRCUITS TO SIGN: ___

HORIZONTAL OR VERTICAL LAMPS: H ___ V ___

COMMENTS



Everbrite

401 S. Main St | P.O. Box 97
Pardeeville, WI 53954
(608) 429-2121